

ACCU-SORT®**Model 20 II**

Compact size and integrated decoder allow for easy integration even in the tightest spaces.

High scan rate increases flexibility, productivity, and efficiency.

Wide scan angle allows bar code scanning even at a close distance.

Reads all bar code densities at a pre-determined mounting distance without the need for optical adjustment.

Optional EM-50 expansion module provides power and terminal block connections.

Small scanner with a tough industrial exterior.

The combination of die cast zinc-aluminum endcaps and an extruded body yields a strong enclosure for applications requiring durability. The three point mounting feature on the base and the side is incorporated in the product to create repeatable mounting in any application. Optional configurations provide high density, long range or high speed capabilities.

The Model 20II's state-of-the-art scanning optics are designed to take the guesswork out of fixed position scanning applications. The unit's flexibility and performance allow it to read the most commonly used bar code densities at pre-defined mounting distances.

Using surface mount technology, a solid-state laser, and a brushless DC motor, we have designed a scanning system into one of the smallest packages available. The NEMA 12 extruded aluminum enclosure measures just 2.6 x 2.3 x 1.6 inches (6.6 x 5.8 x 4.1 cm) and provides protection for internal components in almost any harsh industrial environment.

The Model 20II uses an advanced RISC microprocessor to decode scanned data at very high rates and perform various application functions. The standard configuration provides 13 code types with autodiscrimination of eight bar code symbologies at once. Two parallel outputs selectable for valid and non-valid codes provide external signals to operate small relays.

Our Accu-Setup Suite program provides easy-to-use Windows®-based scanner setup (terminal or host on-line commands are also available). The Model 20 communicates to the host via RS-232-C, RS-422, RS-485 multidrop, or optional 20mA current loop (active or passive).

The compact Model 20 optical decoding and I/O features can accommodate a wide variety of scanning applications. Its small size and single power source enable easy integration into automatic test equipment, blood and chemical analyzers, document scanning systems, print verification, or any fixed position bar code scanning application requiring low-cost non-contact bar code scanners.

Typical applications include:

- Automated and manual medical specimen tracking
- Package content verification
- Automated document handling
- Bar code verification during the printing and binding process

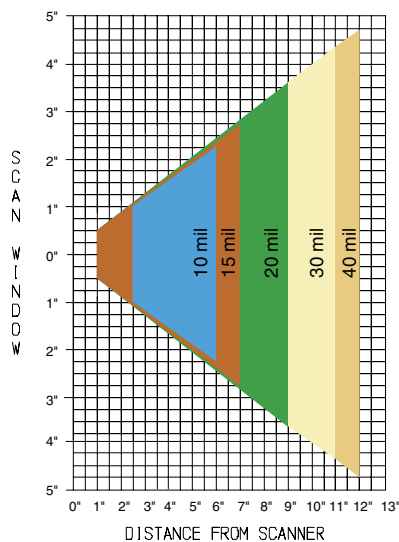

Accu-Sort as the leader in fixed position bar code scanners, offers the Model 20 Series II in its line of inexpensive moving beam scanners.

Model 20 II

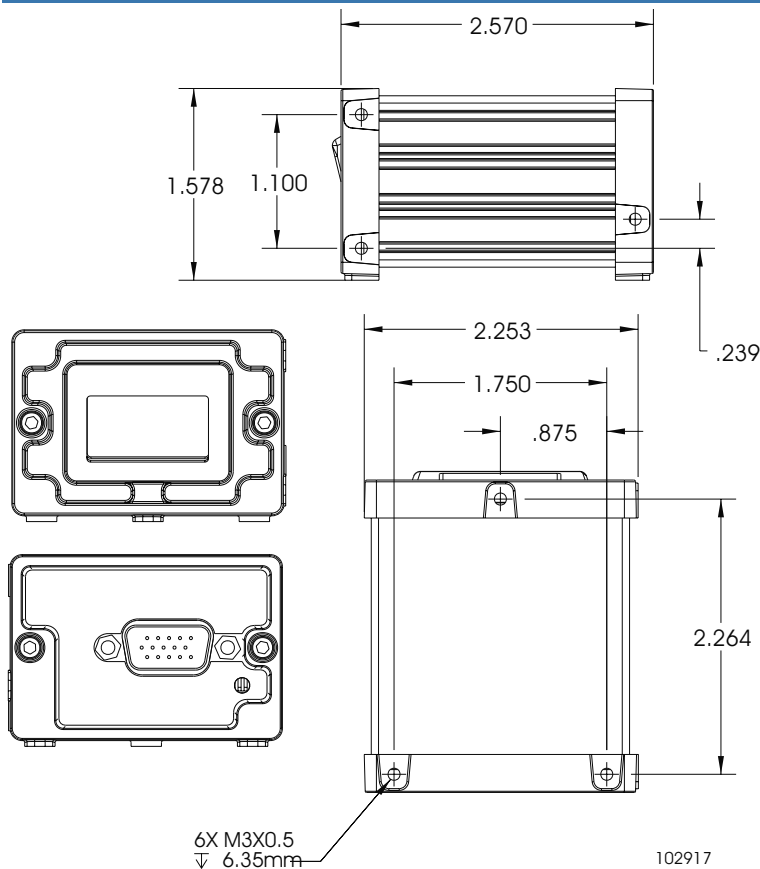

Operational Specifications

Characteristic	Description
Name	Bar Code Laser Scanner, Model 20 II
Depth of Field	See read chart
Scan Rate	500 sps (standard) 300 sps (high density) 500 sps (long range) 700 sps (high speed)
Communication	Programmable I/O (RS-232, RS-422, RS 485 multidrop, DeviceNet (w/ EM50), current loop (optional))
Options	Interface box with relays, Patented DRX, Presence Detector, Raster mirror wheel, Power Supply
Temperature	Operating: 0° to +50° C (+32° to +122° F) Storage: -20° to +70° C (-4° to +158° F)
Relative Humidity	10% - 90% non-condensing
Laser Type	Visible laser diode 650 nM (standard)
Operating Voltage	5 VDC @ 500 mA
Visual Diagnostics	Power, trigger, laser, no/go read
Bar Code Types	All standard 1D symbologies
Connectors	Photoeye, Communications, 15-pin port, Power
Weight	5 oz (140 g)
Size	L 2.6" (6.6 cm) x W 2.3" (5.8 cm) x H 1.6" (4.1 cm)
NEMA Rating	NEMA 12, IP 54
Warranty	1-year limited, parts and labor
Service Options	Installation assistance and on-site training
Approvals	CE, UL, cUL, CDRH 21 CFR 1040 Class II

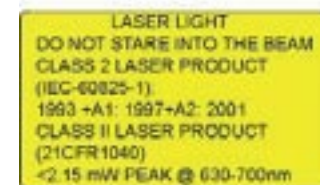

Accu-Sort reserves the right to change specifications without notice.



For more information about auto-ID and material handling solutions from Accu-Sort Systems, contact us at:

ACCUSORT® SYSTEMS, Inc.
511 School House Road
Telford, PA 18969
1-800-BAR-CODE™

info@accusort.com
www.accusort.com



©2003-2005 Accu-Sort Systems, Inc. All rights reserved. The AS logotype, ACCU-SORT, and 1-800-BAR-CODE are trademarks or registered trademarks of Accu-Sort Systems, Inc.