

ACCU-SORT®

AXIOM™ Laser Bar Code Reader



EtherNet/IP™ conformance tested

Scanning Over 1, 2, or 4 Read Zones:

- No focusing required, no dead zones
- Maximum depth of field

Up to 1400 Scans per Second:

- Ensures the highest possible read rates on good and poor quality codes

Modular Scan Head and Wiring Base:

- Simplifies installation
- Reduces repair/replacement downtime

Parameter Storage Modules:

- Store parameters in scan head and base
- Simplifies replacement, no need to remember operating parameters

Flexible Connectivity:

- EtherNet/IP, Ethernet TCP/IP standard
- Serial and I/O standard

AXCESS™ Software:

- Powerful and intuitive interface

The newest laser scanning technology from the leader in bar code scanning

The AXIOM™ bar code readers are designed with industrial and manufacturing applications in mind. Housed in a rugged IP65-rated enclosure, the reliable AXIOM offers high-speed scanning up to 1,400 scans per second. The AXIOM 1L (one-laser version) is designed for use in manufacturing applications with a fixed depth of field and shorter read distances. Where product size and/or positioning varies significantly, the AXIOM 2L and 4L (2 and 4-laser versions) provide accurate bar code reading at distances up to 72 inches.

All AXIOM readers require a universal wiring base and plug-in scan head. The scan head is available in a high-density version for high-speed scanning in fast moving applications.

Sophisticated technology that's easy to use

Although technologically advanced, AXIOM is designed for easy setup and operation. AXCESS™ setup software provides a familiar user interface, enabling you to configure readers without the need for onsite service. Simply connect to AXIOM via setup cable or on-board Ethernet connection. Specify valid bar codes, groups, and patterns. Define your I/O—including built-in trigger and tach signals and up to four solid state relays. When complete, download your application settings to the reader and you're ready to go.

Built-in Parameter Storage Modules store the AXIOM operating parameters in both the scan head and wiring base. In the event replacement ever becomes necessary, just replace the scan head, and the correct parameters are installed with the push a button.

Flexible connectivity... including built-in EtherNet/IP

The AXIOM provides several options for bar code data transfer to your system including: UDP messaging, operation as a TCP/IP client or server, and EtherNet/IP. Use AXCESS software to configure and monitor your AXIOM readers from anywhere in your facility!

These features, along with comprehensive real-time performance monitors, make the AXIOM the leading bar code scanning solution in its class.

AXIOM™ Bar Code Scanning Solutions

Typical AXIOM bar code scanning solutions address these industries and applications:

- Retail/wholesale distribution
- Manufacturing
- Airline baggage
- Tire manufacturing
- Parcel distribution
- Automotive
- High-speed parcel sortation
- High-speed material handling
- Pallet scanning
- Multi-sided arrays
- Package verification
- Print/label verification

Photo captions: (FROM TOP LEFT) AXIOM control panel, AXIOM bar code reader, modular scan head and wiring base. On reverse: AXIOM wiring base with internal wiring diagram/cover.

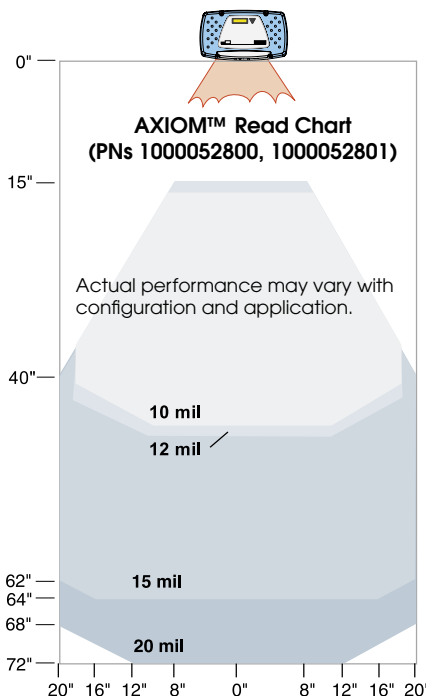

AXIOM™ Laser Bar Code Reader

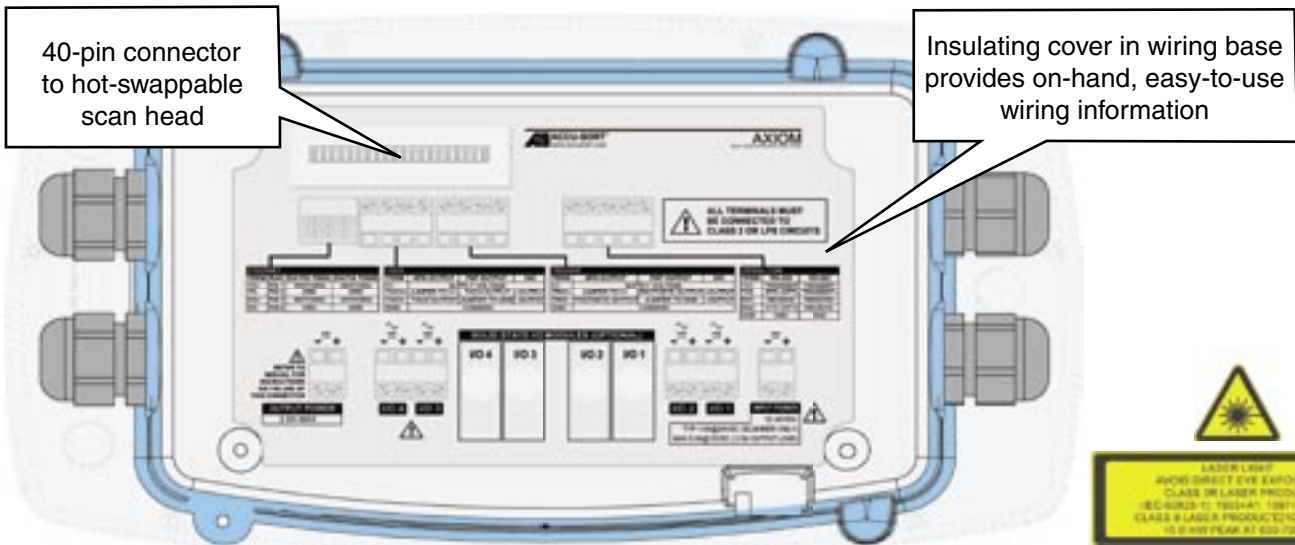

Specifications

Characteristic	Description				
Name/Part Number	Laser Bar Code Reader, AXIOM™				
PN/Specifications	Desc.	Part Number	Min. Bar	Depth of Field	Scans/Second
	1L	1000052807	15 mil+	12-24"	1100
	1L	1000052809	10 mil+	12-18"	1100
	2L	1000052802	15 mil+	22-58"	550
	2L	1000052803	10 mil+	22-35"	550
	2L Enhanced	1000052804	15 mil+	30-72"	1100
	2L Enhanced	1000052805	10 mil+	26-42"	100
	4L	1000052800	15 mil+	15-72"	550
	4L	1000052801	10 mil+	16-42"	550
Communications	Standard: On-board EtherNet/IP, Ethernet TCP/IP, Serial RS232, RS422, and 4 programmable I/O relays Optional: DeviceNet, Profibus				
Options	X-scanning bracket (supports 2 Axiom and power supply) 120 or 240VAC power supply				
Temperature	Operating: +32° to +122° F [0° to +50° C] Storage: -4° to +158° F [-20° to +70° C]				
Relative Humidity	10% - 90% non-condensing				
Laser Type	Visible laser diode 650 nM (standard)				
Power Requirement	12-30 VDC (power supplies available from Accu-Sort)				
Power Consumption	<40 W				
Visual Indicators (LEDs)	Power, trigger, laser status, communications, read quality				
Bar Code Types	All standard 1D symbologies				
Connectors	Dedicated setup port, optional RJ45 connector for Ethernet				
Weight	10 lbs. [4.5 kg]				
Size	L 6.23" [158 mm] x W 10.87" [276 mm] x H 5.19" [132mm]				
Housing	Powder-coated cast aluminum, rated for IP65				
Warranty	1-year limited, parts and labor				
Service Options	Installation assistance and on-site training				

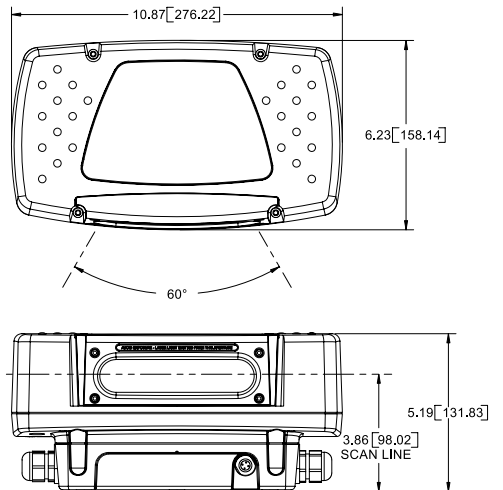

Accu-Sort reserves the right to change specifications without notice.



For more information about auto-ID and material handling solutions from Accu-Sort Systems, contact us at:

ACCUSORT® SYSTEMS, Inc.
511 School House Road
Telford, PA 18969
1-800-BAR-CODE™

info@accusort.com
www.accusort.com



©2003-2005 Accu-Sort Systems, Inc. All rights reserved. ACCU-SORT, 1-800-BAR-CODE, AXIOM, AXCESS, DRX, and the AS logotype are trademarks or registered trademarks of Accu-Sort Systems, Inc.

